

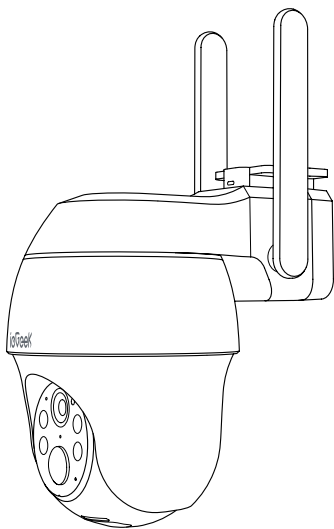

4G LTE
CELLULAR WIRELESS SECURITY CAMERA

USER MANUAL

S11



Sales Email: service@iegeek.com
Official website: <https://www.iegeek.com>



FCC Statement

This equipment has been tested and found to comply with the limits for a Class B digital device, pursuant to part 15 of the FCC rules. These limits are designed to provide reasonable protection against harmful interference in a residential installation. This equipment generates, uses and can radiate radio frequency energy and, if not installed and used in accordance with the instructions, may cause harmful interference to radio communications. However, there is no guarantee that interference will not occur in a particular installation. If this equipment does cause harmful interference to radio or television reception, which can be determined by turning the equipment off and on, the user is encouraged to try to correct the interference by one or more of the following measures:

- Reorient or relocate the receiving antenna.
- Increase the separation between the equipment and receiver.
- Connect the equipment into an outlet on a circuit different from that to which the receiver is connected.
- Consult the dealer or an experienced radio/TV technician for help.

Responsible for compliance could void the user's authority to operate this equipment. (Example- use only shielded interface cables when connecting to computer or peripheral devices). Any Changes or modifications not expressly approved by the party responsible for compliance could void the user's authority to operate the equipment. This equipment complies with Part 15 of the FCC Rules. Operation is subject to the following two conditions:

- 1) This device may not cause harmful interference
- 2) This device must accept any interference received, including interference that may cause undesired operation.

FCC Radiation Exposure Statement:

The equipment complies with FCC Radiation exposure limits set forth for uncontrolled environment. This equipment should be installed and operated with minimum distance 20cm between the radiator and your body.

(FCC ID: 2AYZFS1)



Important Instructions Before Using

- ① Although every effort is made to make the manuals complete and accurate, there may be some discrepancies due to product updates.
- ② The SIM card that comes with the camera provides unlimited for three days of data for free. Please add the data plan in the APP in time after adding the camera successfully.
- ③ To ensure the continuous use of the camera, please ensure that the SIM card has sufficient data, and continue to supplement the data plan for the SIM card.
- ④ The camera is specially designed for motion detection and does not support 24/7 video streaming and recording.
- ⑤ In order to ensure the battery life, it is not recommended to point the camera directly at the road or in a place with a lot of people/vehicles.



CONTENTS

ENGLISH.....	1
DEUTSCH.....	20
FRANÇAIS	32
ESPAÑOL	45
ITALIANO	58

ENGLISH

01	What's in the Box?	1
02	Camera Introduction.....	2
03	Download and Register APP	4
04	Register Account.....	5
05	About SIM card.....	5
06	Power On the Camera.....	6
07	Add the Camera On the Phone.....	6
08	Charge the Camera.....	9
09	Install the Camera.....	10
10	Install the Solar Panel.....	11
11	How do Others Use the Camera?	13
12	Video Management	13
13	PIR Detection and Message Push.....	14
14	Battery Life and Safety Instructions	16
15	FAQs	18

01/What's in the Box?

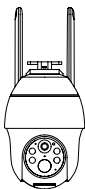

Camera

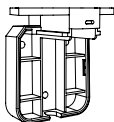

Camera Bracket



Charging Cable

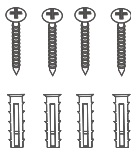

Screw Bag

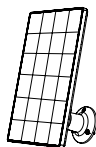

Solar Panel

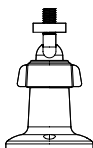

Solar Panel
Bracket

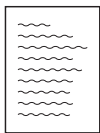

Product Manual

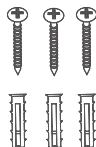

Screw Bag

02/ Camera Introduction

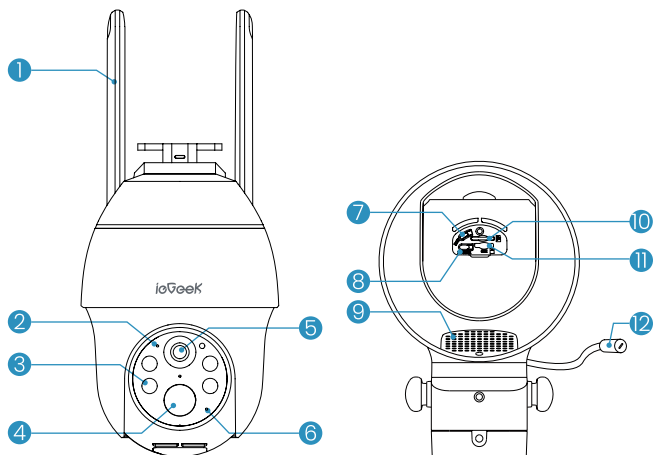

1.	Antenna	2.	Working Status LED
3.	Spotlight & Infrared Light	4.	PIR Motion Sensor
5.	Lens	6.	Microphone
7.	Reset Key	8.	Power Key
9.	Speaker	10.	Micro SD Card Slot
11.	SIM Card Slot	12.	Charging Port

Reset Key	Press and hold RESET for 5 seconds to reset the device (If you have modified the settings, they will revert to the factory default settings)
SD Card Slot	Support local SD card storage (up to 128G)
Lens	Support QHD 2K resolution
Power Light	Red means charging is in progress Blue means charging is complete
Microphone	Capture sound for your videos
PIR Sensor	Can detect moving objects up to 10 meters away
Working Status Light	Red light continuously on: camera network abnormal Red light flashing: waiting for network connection Red and blue lights flash alternately: SIM card recognition failed Blue light flashing slowly: SIM card recognition is successful Solid on blue: 4G internet connected
Speaker	Two-way voice call sound output
Charge Port	Use 5V/2A power supply to charge the camera
Antenna	4G dedicated signal antenna

03/Download and Register APP

Download "ieGeek Cam" APP

Search "ieGeek Cam" in App Store or Google Play, or scan the QR code below to download and install it on your smartphone.



Note: For old users, please update the APP to the latest version.

APP Permission Settings

When using the application for the first time, please turn on the following 2 permissions.

- ① Allow "ieGeek Cam" to access mobile cellular data and WLAN, otherwise you will not be able to add devices.
- ② Allow "ieGeek Cam" to receive messages, otherwise the phone will not receive alert push notifications when motion detection or audible alerts are triggered.

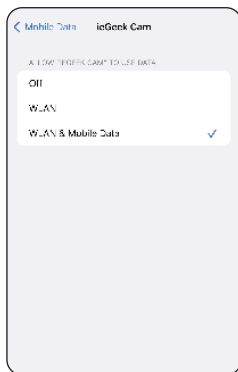
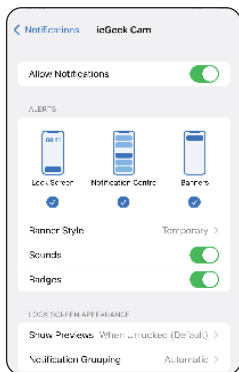

The above is a screenshot of IOS cell phone operation, Android cell phone permissions open method is basically the same as this method.

04/ Register Account

New users must register by email, the concrete steps are as follows:

- ① Click on "Register";
- ② Follow the steps to complete your account registration;
- ③ Login.

Tip:

- ① Please use the correct e-mail.
- ② Please select the correct country code.
- ③ When registering for a new account, please select the region where you are actually located.
(Cameras cannot be shared between different registration regions.)

05/ About SIM card

A SIM card is included in the camera, and this card supports the major carrier networks in your country.

It has the advantages and use, fast and convenient data recharge, strong network compatibility, strong 4G signal, strong compatibility with the camera, no need to sign an agreement with the operator, etc. It is recommended for you to use it.

Note: If your camera has any problems or if you need to use your own SIM card, please contact our after-sales service mailbox: service@iegeek.com.

We will provide you with professional help.

06/Power On the Camera

Press and hold the power button of the camera for 5 seconds until the working indicator on the side of the lens lights up in red, then let go.

Wait for about 30 seconds until the working indicator turns blue light flashing, you will hear the voice prompt "Waiting to connect", which means the camera has successfully connected to the 4G network, and the next step is to add the camera in the APP.

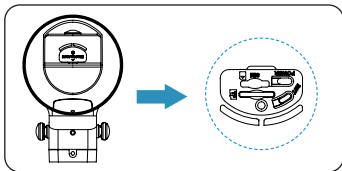

07/Add the Camera On the Phone

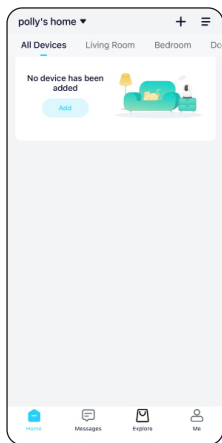

Tap '+' to Add Device

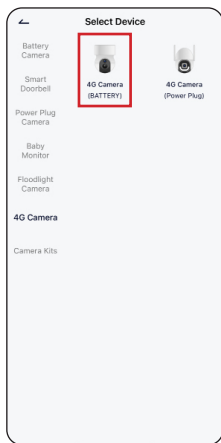

Select 4G Camera

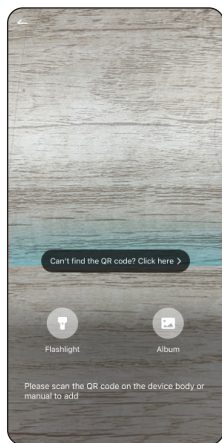

Scan QR Code

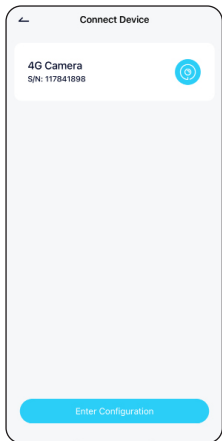

Click to Configure



Insert SIM Card



Power on Camera

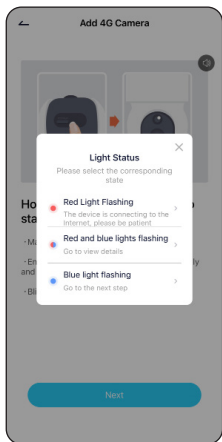

Wait for SIM card recognition

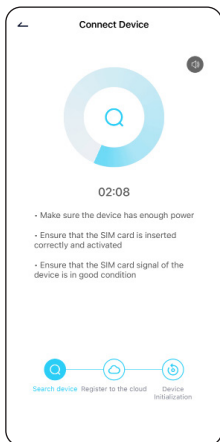

Wait for Connection

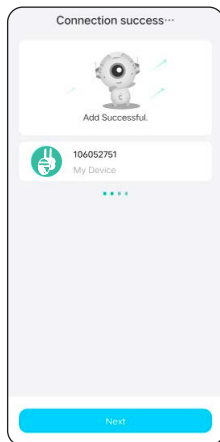

Device Added

Add failed? Please refer to the following to resolve the issues:

Camera voice prompt : Wait for connection time out	Solutions : Press the power button to restart
Working light status : Indicator light off	
Camera status : If the network is not configured for a long time, the device will automatically sleep	

Camera voice prompt : No LTE signal	Solutions : <ol style="list-style-type: none">1. Please check if your SIM card's data plan is available2. The current 4G signal is weak, please move the camera to a better signal location
Working light status : Red light keeps flashing	
Camera status : SIM card has no data plan or 4G signal difference	

Note: If you try to add a camera several times and still fail, please contact the customer service staff for help.

08/charge the Camera

It is recommended to fully charge the camera battery before installing the camera outdoors.

Charge the camera with a standard and high-quality 5V power adapter (not included).

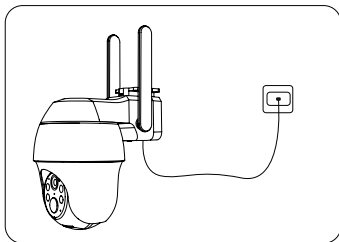
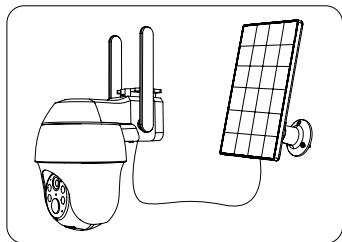

Use the solar panel to charge the camera.

Safety Reminder: Do not use a non-5V power adapter to charge the camera, and do not charge near fire and heaters. If the battery emits odor, heat, deformation and other abnormal conditions during the charging process, please stop charging or using it immediately.

09/Install the Camera

Notes before installation:

- In order to ensure that the camera can obtain a good network signal, please install the camera in a location with good signal and no signal interference.
- In order to avoid frequent alarms and rapid battery consumption, do not point the camera directly at the road or in crowded places.
- Make sure there are no reflections within 5 feet (1.5 meters) of the PIR sensor, otherwise it will interfere with the normal function of the sensor.

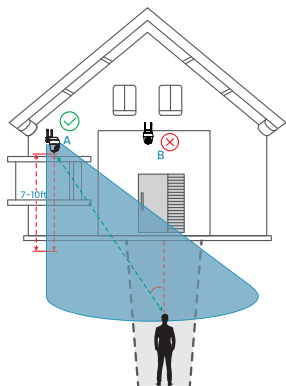

- For outdoor use, the camera must be installed forward for better waterproof performance and better PIR motion sensor efficiency.
- In order to ensure better waterproof performance, after installation, please ensure that all rubber plugs on the surface of the camera are covered.
- In order to better connect the 4G network, it is recommended to install the antenna upward or horizontally.
- Install the camera 2-3 meters (7-10ft) above the ground. This height maximizes the detection range of the PIR motion sensor.

- Do not place the camera exactly in the direction of the intruder's movement. The angle formed by the connection between the PIR sensor and the intruder and the intruder's walking route must be greater than 20 degrees.

Note: As shown in the picture, the red dotted line is the usual intrusion path of the intruder, then point A is the best installation location for the camera, if it is installed at point B, it may cause a missed alarm.

Installation Step:

Step 1: Use Power Drill and two screws to fix the camera bracket on the wall. It is recommended that the bracket be 7-10 ft above the ground (2-3 meters)

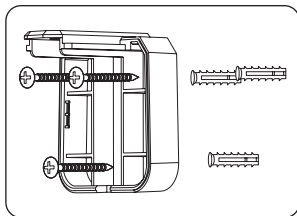

Step 2: Clip the camera base into the bracket from top to bottom, and the installation is completed

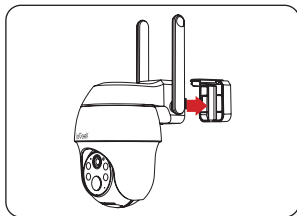

Note: To remove the camera from the wall, press the snap position under the bracket with your finger, and then pull out the camera.

10/ Install the Solar Panel

Please use the plastic brackets and screws included in the box to install the solar panel.

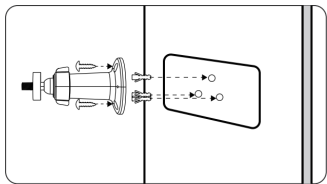

Step 1: Using the power drill and screws, fasten the plastic bracket of the solar panel to the wall.

Note: In order to obtain the best charging efficiency, the solar panel must be installed in a location with sufficient sunlight (it is recommended that there be no light shielding around), and the daily light time can be guaranteed to be more than 4 hours.

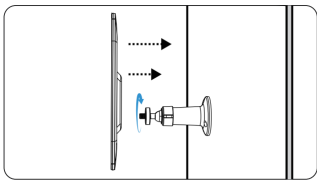

Step 2: Align the screw cap of the bracket with the screw hole on the back of the solar panel and rotate it clockwise to fix it.

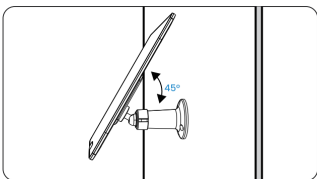

Step 3: Adjust the angle of the solar panel according to the actual environment, and ensure that the front of the panel is facing up (45° angle is the best inclination angle).

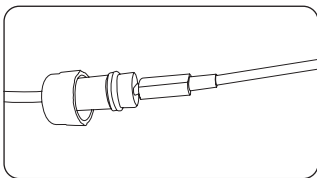

Step 4: Insert the solar panel charging head into the camera charging port correctly.

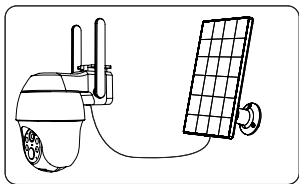

Step 5: Installation is completed.

Note: To ensure the charging efficiency of the solar panel, please clean the panel surface regularly.

Note: In rainy days and cold winters, the charging efficiency of the solar panel will be very low. If the battery of the camera will run out, please remove the camera, take it indoors and use the 5V power adapter to fully charge it, and then install it back.

11/ How do Others Use the Camera?

In order to ensure the security of the camera, the camera is only allowed to be added by one account. If others need to access the camera simultaneously, they can use the "Device Share" function.

Sharing Steps:

- ① Others first download and install the camera's APP, register a new account and log in (the country selected during registration must be the same as your choice).
 - ② You click "Device Share" in the APP, please watch the operation video first, and follow the video steps to complete the sharing.
- Tip:** When sharing, you need to select the permission of the camera, please choose according to actual needs.
- ③ He will receive a push message on his APP, click "Accept" to complete the sharing.

12/ Video Management

The camera needs a Micro SD card to store video files. Insert the Micro SD card into the SD card slot of the camera correctly.

SD card requirements:

- ① Recommend the use of brand name cards such as San Disk, Samsung, etc.
- ② Support 2-128GB capacity;
- ③ Recommend the use of standard Class 10 SD cards.
- ④ Only FAT32 format is supported (you can select FAT32 to format the SD card after inserting the SD card into the computer).

When the camera detects an intruder, it will automatically save the video file to the SD card.

How to download SD card video to mobile phone or computer?

- ① When playing the historical video in the APP, select the video clip you want to download, and click Download.
- ② After inserting the SD card into the computer or mobile phone, look for the required video files. The video file is in MP4 format, and you can play it directly with the player.

13 / PIR Detection and Message Push

In order to obtain the alarm message push function, please enable the push permission of the APP in the mobile phone system.

The camera has a wealth of motion detection setting options, including: "motion detection sensitivity", "work mode", "alarm plan", "alarm area setting", "AI humanoid detection" and other functions.

Enter the application, select the device, and enter "Parameter Settings" → "Alarm Management" to flexibly set the camera's alarm detection function.

Introduction to PIR motion detection sensitivity:

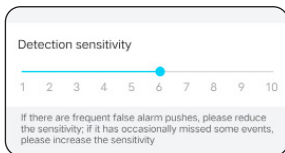

1-3 belongs to the low gear sensitivity, motion detection distance of 3-5 meters.

4-7 belongs to the medium gear sensitivity, motion detection distance of 5-7 meters.

8-10 belongs to the high gear sensitivity, motion detection distance of 7-10 meters.

Introduction of AI humanoid detection function:

In "Alarm Management" → "Custom Mode", there are two options of "Daytime Humanoid Detection" and "Night Humanoid Detection", and the camera is turned on by default. After the humanoid detection function is turned on, the camera will start an alarm when only humanoids are moving, and vehicles/animals will not be detected. If you need the camera to detect vehicles and animals normally, please turn off human detection.

You may encounter the following situations:

Problems and failures	Solutions
The phone receives frequent alarm messages	<ol style="list-style-type: none">① Reduce the sensitivity of motion detection② Enable the humanoid detection function③ Set the alarm area④ Avoid the camera facing the roadside or crowded places
There are no moving objects in the alarm picture	<ol style="list-style-type: none">① Reduce the motion detection sensitivity② Enable the humanoid detection function
Someone passed by without alarms	<ol style="list-style-type: none">① Check whether the message push permission is enabled② Increase the sensitivity of motion detection③ Avoid intruders from walking vertically to the camera
Frequent leakage alarms at night	<ol style="list-style-type: none">① Make sure the image quality at night is normal② Turn off "Night Humanoid Check"
Mobile alarm is not timely, obviously delayed	<ol style="list-style-type: none">① Increase the sensitivity of motion detection② Avoid intruders from walking vertically to the camera③ Check whether the network of the camera and mobile phone is good

14/ Battery Life and Safety Instructions

This camera is not designed for 24/7 operation and 24/7 recording, but designed for recording motion detection, which can be viewed remotely only when you need it.

Reasons for short battery life	Solutions to improve battery life
The PIR sensor is frequently triggered, repeatedly waking up the camera to work.	<ul style="list-style-type: none">① Reduce the sensitivity of motion detection.② Enable the humanoid detection function.③ Set the alarm area④ Avoid the camera facing the roadside or crowded places.
Frequent and long-term remote viewing of videos on mobile phones	Reduce the frequency and time of watching videos remotely
The network is very poor, causing the camera to search the network frequently and automatically	Determine whether the 4G network signal around the camera is poor, avoid objects that interfere with the signal around, and move the camera to a position with better signal
In low temperature and cold weather, battery performance will be reduced and solar charging efficiency will decrease	In cold weather, reduce the sensitivity of motion detection, turn on the humanoid detection function, set the alarm area, and reduce the working time of the camera

<p>Inefficient or no charging of solar panels</p>	<ol style="list-style-type: none"> ① Ensure that the solar panel can receive sufficient sunlight ② Check whether the solar panel is faulty ③ Regularly clean the surface of the panel ④ Check whether the charging port is in poor contact or faulty
<p>Camera consumes power faster than solar charging efficiency</p>	<p>Refer to the solution above</p>

Reminder: If the above attempts still cannot solve the problem of short battery life, please contact the customer service staff (service@iegeek.com) for help.

Battery Safety Instructions:

- If the battery of the camera is about to run out, please remove the camera, take it indoors and use the 5V power adapter to fully charge it, and then install it back.
- Do not violently damage the battery with sharp tools, it may cause battery failure.
- Please keep the camera charging port dry and clean.
- Please use a standard and high-quality 5V power adapter to charge the camera, please do not use a non-5V power adapter to charge the camera.
- Do not charge, use or place the camera near fire and heaters, if the battery emits abnormal conditions such as odor, heat, deformation, etc., please stop charging or use it immediately.

15/FAQs

For more detailed FAQs, please log in the APP, "Me"- "Help"- "4G Camera".

Q: The camera cannot be turned on?

A: ① Make sure the camera is fully charged. Please use the 5V power adapter to fully charge the camera before turning it on.
② If the camera is faulty or water has entered, please contact the customer service staff (service@iegeek.com) for help.

Q: Failed to add camera?

A: Please go back to page 9-11 to find solutions, or contact the customer service (service@iegeek.com) for help.

Q: After the first use for a period of time, the camera fails to connect to the internet?

A: ① If you use the SIM card that comes with the camera, unlimited for three days data plan will be given for free. To avoid running out of data, please replenish the data plan in the APP in time.
② Please check whether the SIM card data plan is normal, such as arrears, excessive data usage, etc., and regularly supplement the data plan for the SIM card.
③ Please check whether the 4G network signal around the camera is good, and avoid signal interference around.

Q: The camera drops frequently and cannot be connected?

A: Please check whether the 4G network signal around the camera is good, and avoid signal interference around.

Q: Can't the mobile phone receive the alarm push message?

A: ① Check whether the message push permission of the app has been enabled in the system settings of the mobile phone.
② Restart the phone, and the Android phone will try to clear the cache.
③ Check whether the camera has the motion detection function enabled.
④ Check whether the network of the camera and mobile phone is good.
⑤ Check whether the camera is online, and check whether the SIM

card data plan is normal, such as arrears, excessive data usage, etc.

Q: Motion detection missed alarm?

A: ① Increase the motion detection sensitivity of the camera.

② Please install the camera correctly to avoid intruders from walking vertically to the camera. (For the solution, please refer to the text of "Installing the Camera" in the manual).

③ If you need to detect vehicles or animals, please turn off the "AI humanoid detection" function.

Q: Can the camera connect to Wi-Fi?

A: Wi-Fi is not supported, only 4G network is supported.

Q: How much data does the camera consume per month?

A: The traffic consumed by the camera depends on the resolution you select when viewing. The higher the resolution, the greater the traffic consumption. The longer the preview video and video playback time, the greater the data consumption. The more times the PIR sensor is triggered, the greater the flow digestion.

Q: The subscription data plan package does not take effect, or do I need to transfer the package and refund the fee?

A: Our camera contains a SIM card. After the recharge is successful, there may be a delay in the activation of the data package. Please contact our email service@iegeek.com.

DEUTSCH

01	Wichtige Anweisungen vor der Verwendung.....	21
02	SIM-Karte.....	21
03	Kamera Einführung	22
04	APP Herunterladen und Registrieren	24
05	Fügen Sie die Kamera auf dem Telefon Hinzu.....	25
06	Laden Sie die Kamera auf	28
07	Installieren Sie die Kamera.....	29
08	Erfassungsbereich des PIR-Sensors	29
09	Häufig Gestellte Fragen.....	30

01/ Wichtige Anweisungen vor der Verwendung

- ① Obwohl alle Anstrengungen unternommen werden, um die Handbücher vollständig und genau zu machen, kann es aufgrund von Produktaktualisierungen zu Abweichungen kommen.
- ② Die mit der Kamera gelieferte SIM-Karte bietet nur 100 MB Daten kostenlos. Bitte fügen Sie den Datenplan rechtzeitig in der APP hinzu, nachdem Sie die Kamera erfolgreich hinzugefügt haben.
- ③ Um die kontinuierliche Nutzung der Kamera zu gewährleisten, stellen Sie bitte sicher, dass die SIM-Karte über ausreichend Daten verfügt, und ergänzen Sie weiterhin den Datenplan für die SIM-Karte.
- ④ Die Kamera wurde speziell für die Bewegungserkennung entwickelt und unterstützt kein 24/7-Videostreaming und -aufzeichnung.
- ⑤ Um die Batterielebensdauer zu gewährleisten, wird empfohlen, die Kamera nicht direkt auf die Straße oder auf einen Ort mit vielen Menschen/Fahrzeugen zu richten.

02/ SIM-Karte

Eine SIM-Karte ist in der Kameraverpackung und diese Karte unterstützt die großen Netzbetreiber in Ihrem Land.

Es hat die Vorteile einer und Verwendung, eines schnellen und bequemen Aufladens von Daten, einer starken Netzwerkkompatibilität, eines starken 4G-Signals, einer starken Kompatibilität mit der Kamera, keine Notwendigkeit, eine Vereinbarung mit dem Betreiber zu unterzeichnen usw. Es wird Ihnen empfohlen, es zu verwenden.

Hinweis: Wenn Sie Probleme mit Ihrer Kamera haben oder Ihre eigene SIM-Karte verwenden müssen, kontaktieren Sie uns bitte: service@iegeek.com.

03/ Kamera Einführung

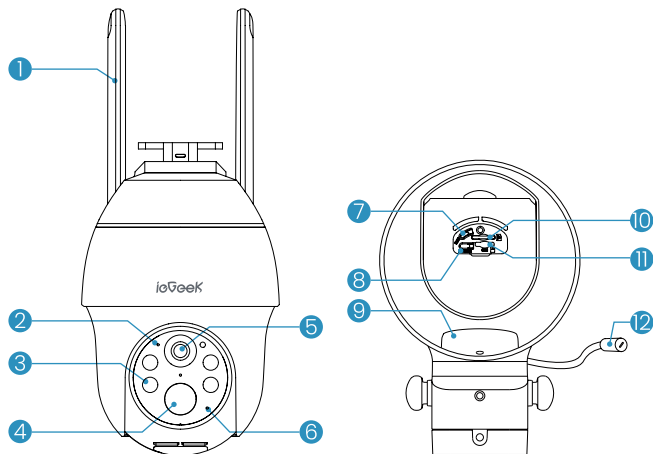

1.	Antenne	2.	Arbeitsstatus-LED
3.	Spotlight & Infrarot-Licht	4.	PIR-Bewegungssensor
5.	Objektiv	6.	Mikrofon
7.	Reset-Taste	8.	Power-Taste
9.	Lautsprecher	10.	Micro SD-Kartenschlitz
11.	SIM-Kartenschlitz	12.	Ladeanschluss

Einschalttaste	Halten Sie die Einschalttaste 5 Sekunden lang gedrückt, um die Kamera einzuschalten
Schlüssel zurücksetzen	Halten Sie RESET 5 Sekunden lang gedrückt, um das Gerät zurückzusetzen (Wenn Sie die Einstellungen geändert haben, werden sie auf die werkseitigen Standardeinstellungen zurückgesetzt).
SD-Kartensteckplatz	Unterstützt lokalen SD-Kartenspeicher (bis zu 128 GB)
Power-Licht	Rot bedeutet, dass der Ladevorgang läuft Blau bedeutet, dass der Ladevorgang abgeschlossen ist
PIR-Sensor	Kann sich bewegende Objekte bis zu einer Entfernung von 10 Metern erkennen
Arbeitsstatusleuchte	Rotes Licht dauerhaft an: Kameranetzwerk anormal Rotes Licht blinkt: Warten auf Netzwerkverbindung Rote und blaue Lichter blinken abwechselnd: Erkennung der SIM-Karte fehlgeschlagen Blaues Licht blinkt langsam: Erkennung der SIM-Karte erfolgreich Fest auf blau: 4G-Internetverbindung.
Ladeanschluss	Verwenden Sie ein 5-V-/2-A-Netzteil, um die Kamera aufzuladen

04/ APP Herunterladen und Registrieren

Laden Sie die „ieGeek Cam“-APP Herunter

Suchen Sie im App Store oder bei Google Play nach „ieGeek Cam“ oder scannen Sie den QR-Code unten, um ihn herunterzuladen und auf Ihrem Smartphone zu installieren.



Hinweis: Für alte Benutzer aktualisieren Sie bitte die APP auf die neueste Version.

APP-Berechtigungseinstellungen

Wenn Sie die Anwendung zum ersten Mal verwenden, aktivieren Sie bitte die folgenden 2 Berechtigungen.

- ① Erlauben Sie „ieGeek Cam“ den Zugriff auf Mobilfunkdaten und WLAN, sonst können Sie keine Geräte hinzufügen.
- ② Erlauben Sie "ieGeek Cam", Nachrichten zu empfangen, andernfalls erhält das Telefon keine Alarm-Push-Benachrichtigungen, wenn Bewegungserkennung oder akustische Alarme ausgelöst werden.

Das Folgende ist ein Screenshot des IOS-Handy-Betriebs, die Methode zum Öffnen von Android-Handy-Berechtigungen ist im Grunde die gleiche wie diese Methode.

Konto Registrieren

Neue Benutzer müssen sich per E-Mail registrieren, die konkreten Schritte sind wie folgt:

- ① Klicken Sie auf „Registrieren“;
- ② Folgen Sie den Schritten, um Ihre Kontoregistrierung abzuschließen;
- ③ Anmelden.

Tipps:

- ① Bitte verwenden Sie die richtige E-Mail-Adresse.
- ② Bitte wählen Sie den richtigen Ländercode.
- ③ Wenn Sie sich für ein neues Konto registrieren, wählen Sie bitte die Region aus, in der Sie sich tatsächlich befinden. (Kameras können nicht zwischen verschiedenen Registrierungsregionen geteilt werden.)

05/ Fügen Sie die Kamera auf dem Telefon hinzu

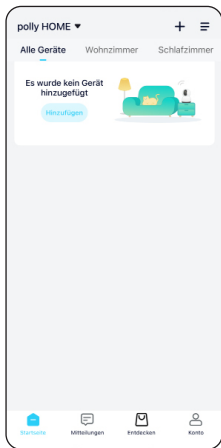

Tippen Sie auf „+“, um ein Gerät hinzuzufügen

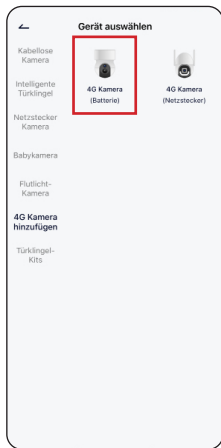

Wählen Sie 4G-Kamera

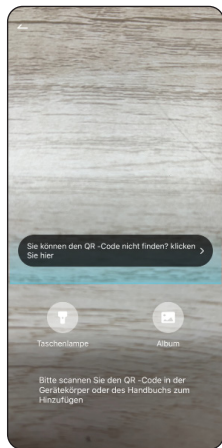

QR-Code scannen

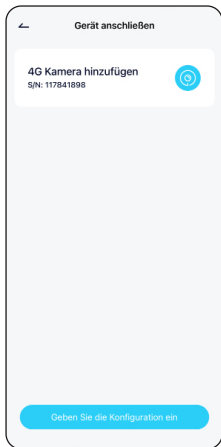

Klicken Sie zum Konfigurieren



Setzen Sie die SIM-Karte ein



Öffnen Sie die Kamera

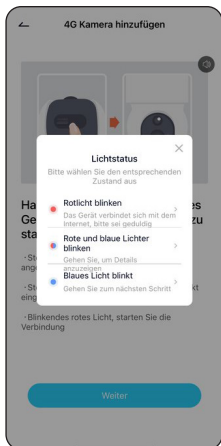

Warten Sie, bis die SIM-Karte erkannt wird



Warten Sie auf die Verbindung

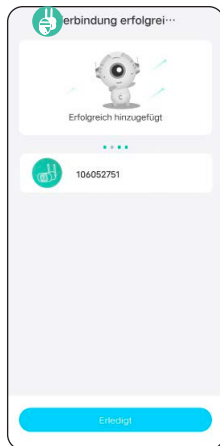

Gerät hinzufügen

Hinzufügen fehlgeschlagen? Bitte beachten Sie Folgendes, um die Probleme zu lösen:

Sprachansage der Kamera : Warten Sie auf das Verbindungs-Timeout	Lösungen : Drücken Sie den Netzschalter, um neu zu starten
Arbeitslichtstatus : Kontrollleuchte aus	
Kamerastatus : Wenn das Netzwerk längere Zeit nicht konfiguriert wird, geht das Gerät automatisch in den Ruhezustand	

Hinweis: Wenn Sie mehrmals versuchen, eine Kamera hinzuzufügen und immer noch fehlschlagen, senden Sie bitte Ihre Bestellung und Ihr Problem an service@iegeek.com.

06/Laden Sie die Kamera auf

Es wird empfohlen, den Kameraakku vollständig aufzuladen, bevor Sie die Kamera im Freien installieren.

Laden Sie die Kamera mit einem handelsüblichen und hochwertigen 5-V-Netzteil (nicht im Lieferumfang enthalten).

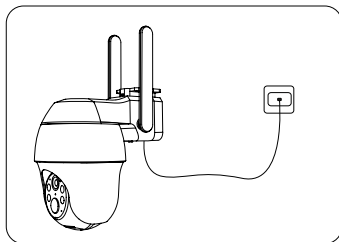
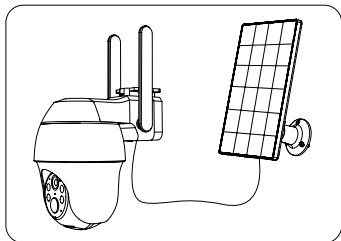

Verwenden Sie das Solarpanel, um die Kamera aufzuladen.

Sicherheitserinnerung: Verwenden Sie zum Aufladen der Kamera keinen anderen als 5-V-Netzadapter und laden Sie sie nicht in der Nähe von Feuer oder Heizkörpern auf. Wenn der Akku während des Ladevorgangs Geruch, Hitze, Verformung oder andere anormale Bedingungen abgibt, beenden Sie bitte den Ladevorgang oder verwenden Sie ihn sofort.

07/ Installieren Sie die Kamera

Hinweise vor der Installation:

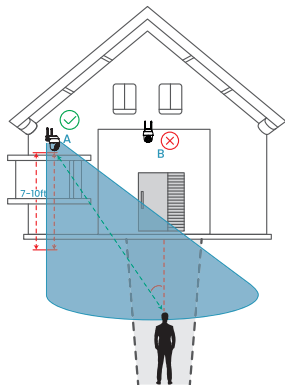

- Installieren Sie die Kamera 2-3 Meter (7-10 Fuß) über dem Boden. Der Erfassungsbereich von
- der Bewegungssensor würde bei einer solchen Höhe maximiert werden.
- Für eine effektive Bewegungserkennung installieren Sie die Kamera bitte schräg.
- HINWEIS: Wenn sich ein sich bewegendes Objekt vertikal dem PIR-Sensor nähert, kann die Kamera die Bewegung möglicherweise nicht erkennen.

08/ Erfassungsbereich des PIR-Sensors

Der PIR-Erfassungsbereich kann an Ihre speziellen Anforderungen angepasst werden. Sie können sich auf die folgende Tabelle beziehen, um es in den Geräteeinstellungen über die ieGeek Cam App einzurichten.

Empfindlichkeit	Erkennungsabstand (für bewegliche und lebende Objekte)
Stufe 1-3 (Niedrig)	Bis zu 3-5 Meter
Stufe 4-7 (Mittel)	Bis zu 5-7 Meter
Stufe 8-10 (Hoch)	Bis zu 7-10 Meter

09/Häufig Gestellte Fragen

Für detailliertere FAQs melden Sie sich bitte in der APP an, "Me" - "Hele" - "4G Camera".

Q: Die Kamera lässt sich nicht einschalten?

A: ① Stellen Sie sicher, dass die Kamera vollständig aufgeladen ist. Bitte verwenden Sie das 5-V-Netzteil, um die Kamera vollständig aufzuladen, bevor Sie sie einschalten.

② Sollte die Kamera defekt sein oder Wasser eingedrungen sein, wenden Sie sich bitte an den Kundendienst des Markenherstellers.

Q: Kamera konnte nicht hinzugefügt werden?

A: Bitte gehen Sie zurück zu Seite 9, um Lösungen zu finden, oder wenden Sie sich an das Kundendienstpersonal der Marke, um Hilfe zu erhalten.

Q: Nach der ersten Verwendung über einen bestimmten Zeitraum hinweg kann die Kamera keine Verbindung zum Internet herstellen?

A: ① Bitte überprüfen Sie, ob der Datenplan der SIM-Karte normal ist, wie z. B. Zahlungsrückstände, übermäßige Datennutzung usw., und ergänzen Sie regelmäßig den Datenplan für die SIM-Karte.

② Bitte überprüfen Sie, ob das 4G-Netzwerksignal um die Kamera herum gut ist, und vermeiden Sie Signalstörungen in der Umgebung.

Q: Die Kamera fällt häufig herunter und kann nicht verbunden werden?

A: Bitte überprüfen Sie, ob das 4G-Netzwerksignal um die Kamera herum gut ist, und vermeiden Sie Signalstörungen in der Umgebung.

Q: Kann das Handy die Alarm-Push-Nachricht nicht empfangen?

A: ① Überprüfen Sie, ob die Nachrichten-Push-Berechtigung der App in den Systemeinstellungen des Mobiltelefons aktiviert wurde.

② Starten Sie das Telefon neu und das Android-Telefon versucht, den Cache zu leeren.

③ Überprüfen Sie, ob die Bewegungserkennungsfunktion der Kamera aktiviert ist.

④ Überprüfen Sie, ob das Netzwerk der Kamera und des Mobiltelefons gut ist.

⑤ Überprüfen Sie, ob die Kamera online ist, und überprüfen Sie, ob der Datentarif der SIM-Karte normal ist, z. B. Zahlungsrückstände,

übermäßige Datennutzung usw.

Q: Verpasster Alarm durch Bewegungserkennung?

A: ① Erhöhen Sie die Bewegungserkennungsempfindlichkeit der Kamera.

② Bitte installieren Sie die Kamera korrekt, um zu verhindern, dass Eindringlinge senkrecht zur Kamera gehen. (Die Lösung finden Sie im Text „Installieren der Kamera“ im Handbuch).

③ Wenn Sie Fahrzeuge oder Tiere erkennen müssen, schalten Sie bitte die Funktion "AI Humanoid Detection" aus.

Q: Kann sich die Kamera mit Wi-Fi verbinden?

A: Wi-Fi wird nicht unterstützt, nur 4G-Netzwerke werden unterstützt.

Q: Wie viele Daten verbraucht die Kamera pro Monat?

A: Der von der Kamera verbrauchte Datenverkehr hängt von der Auflösung ab, die Sie beim Anzeigen auswählen. Je höher die Auflösung, desto größer der Verkehrsverbrauch. Je länger das Vorschauvideo und die Videowiedergabezeit, desto höher der Datenverbrauch. Je öfter der PIR-Sensor ausgelöst wird, desto größer ist die Strömungsverdauung.

Q: Das Abonnement-Datenplanpaket wird nicht wirksam, oder muss ich das Paket übertragen und die Gebühr erstatten?

A: Wenn Sie die kameraeigene SIM-Karte verwenden, wenden Sie sich bitte an den Kundendienst des Markenherstellers der Kamera, um Hilfe zu erhalten.

Wenn Sie alle Schritte ausprobiert haben, aber immer noch kein Glück haben, senden Sie bitte Ihre Bestellung und Ihr Problem an service@iegeek.com

FRANÇAIS

01	Instructions Importantes Avant Utilisation.....	33
02	Carte SIM	33
03	Présentation de la Caméra	34
04	Téléchargez et Enregistrez L'application	36
05	Ajouter Caméra sur le Téléphone.....	37
06	Charger la Caméra.....	40
07	Installer la Caméra	41
08	Plage de Détection du Capteur PIR	41
09	FAQs	42

01/ Instructions Importantes Avant Utilisation

- ① Bien que tous les efforts soient faits pour que les manuels soient complets et précis, il peut y avoir des divergences dues aux mises à jour des produits.
- ② La carte SIM fournie avec caméra ne fournit que 3 jours illimités de données gratuitement. Veuillez ajouter le plan de données dans l'APP à temps après avoir ajouté la caméra avec succès.
- ③ Pour garantir l'utilisation continue de caméra, veuillez vous assurer que la carte SIM contient suffisamment de données et continuer à compléter le plan de données de la carte SIM.
- ④ La caméra est spécialement conçue pour la détection de mouvement et ne prend pas en charge la diffusion et l'enregistrement vidéo et 24/7.
- ⑤ Afin de garantir la durée de vie de la batterie, il n'est pas recommandé de pointer la caméra directement vers la route ou dans un endroit avec beaucoup de personnes/véhicules.

02/ Carte SIM

Une carte SIM est incluse dans la boîte de caméra et cette carte prend en charge les principaux réseaux d'opérateurs de votre pays.

Il présente les avantages d'une installation et d'une utilisation faciles, d'une recharge de données rapide et pratique, d'une forte compatibilité réseau, d'un signal 4G fort, d'une forte compatibilité avec la caméra, pas besoin de signer un accord avec l'opérateur, etc. Il vous est recommandé de l'utiliser.

Si vous avez des problèmes ou si vous devez utiliser votre propre carte SIM, veuillez nous contacter à ieGeek.

03/Présentation de la Caméra

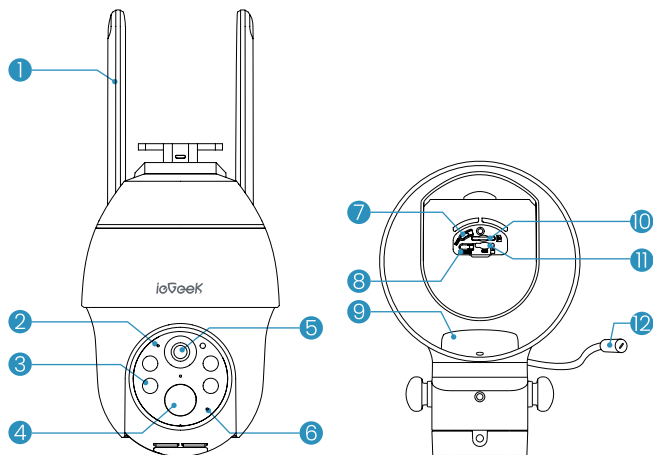

1.	Antenne	2.	LED d'état de fonctionnement
3.	Projecteur et lumière infrarouge	4.	Capteur de mouvement PIR
5.	Lentille	6.	Microphone
7.	Touche de réinitialisation	8.	Touche d'alimentation
9.	Haut-parleur	10.	Fente pour carte Micro SD
11.	Fente pour carte SIM	12.	Port de charge

Clé D'alimentation	Appuyez et maintenez enfoncé le bouton d'alimentation pendant 5 secondes pour allumer caméra
Touche de Réinitialisation	Appuyez et maintenez enfoncé RESET pendant 5 secondes pour réinitialiser l'appareil (si vous avez modifié les paramètres, ils reviendront aux paramètres d'usine par défaut)
Fente pour Carte SD	Prise en charge du stockage local sur carte SD (jusqu'à 128G)
Voyant D'alimentation	Rouge signifie que la charge est en cours Le bleu signifie que la charge est terminée
Capteur PIR	Peut détecter des objets en mouvement jusqu'à 10 mètres
Voyant d'état de Fonctionnement	Voyant rouge allumé en continu: réseau de caméras anormal Voyant rouge clignotant: en attente de connexion réseau Les voyants rouges et bleus clignotent alternativement: la reconnaissance de la carte SIM a échoué Voyant bleu clignotant lentement: la reconnaissance de la carte SIM est réussie Lumière bleue toujours allumée : connexion à l'internet 4G
Prise de Charge	Utilisez une alimentation 5V/2A pour charger la caméra

04/ Téléchargez et Enregistrez L'application

Téléchargez L'application "ieGeek Cam"

Recherchez "ieGeek Cam" dans App Store ou Google Play, ou scannez le code QR ci-dessous pour le télécharger et l'installer sur votre smartphone.



Remarque: Pour les anciens utilisateurs, veuillez mettre à jour l'APP vers la dernière version.

Paramètres D'autorisation APP

Lorsque vous utilisez l'application pour la première fois, veuillez activer les 2 autorisations suivantes.

- ① Autorisez "ieGeek Cam" à accéder aux données cellulaires mobiles et au WLAN, sinon vous ne pourrez pas ajouter d'appareils.
- ② Autorisez "ieGeek Cam" à recevoir des messages, sinon le téléphone ne recevra pas de notifications push d'alerte lorsque la détection de mouvement ou les alertes sonores sont déclenchées.

Ce qui suit est une capture d'écran du fonctionnement du téléphone portable IOS, la méthode d'ouverture des autorisations du téléphone portable Android est fondamentalement la même que cette méthode.

Créer un Compte

Les nouveaux utilisateurs doivent s'inscrire par email, les étapes concrètes sont les suivantes :

- ① Cliquez sur "S'inscrire" ;
- ② Suivez les étapes pour terminer l'enregistrement de votre compte ;
- ③ Connexion.

Des Astuces:

- ① Veuillez utiliser le bon e-mail.
- ② Veuillez sélectionner le bon code pays.
- ③ Lors de l'enregistrement d'un nouveau compte, veuillez sélectionner la région où vous vous trouvez réellement. (Les caméras ne peuvent pas être partagées entre différentes régions d'enregistrement.)

05/ Ajouter Caméra sur le Téléphone

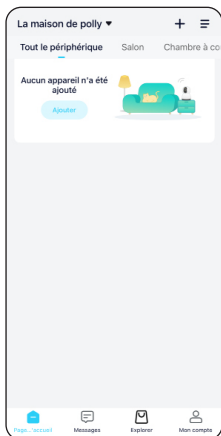

Appuyez sur '+' pour ajouter un appareil

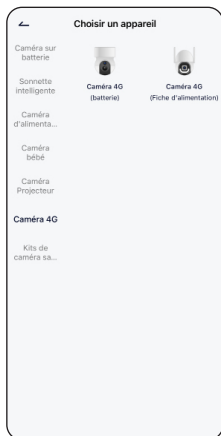

Sélectionnez la caméra 4G

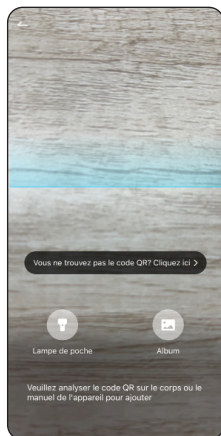

Scanner OU Coder

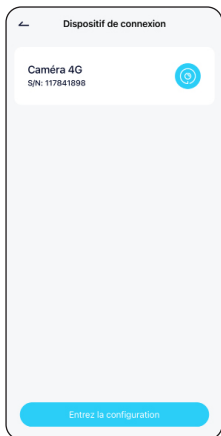

Cliquez pour configurer



Insérer la carte SIM

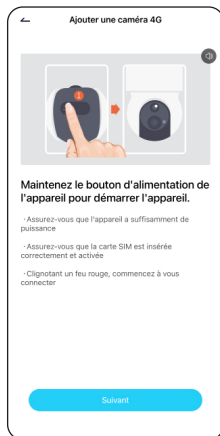

Allumez caméra

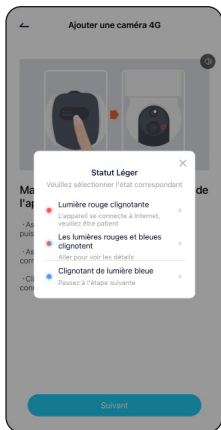

Attendez la reconnaissance de la carte SIM

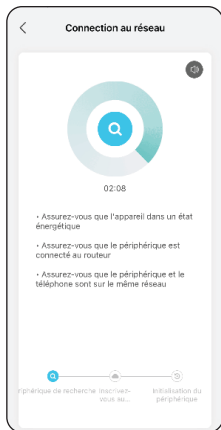

Attendez la connexion

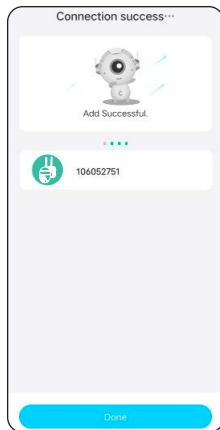

Appareil ajouté

L'ajout a échoué? Veuillez vous référer à ce qui suit pour résoudre les problèmes:

Invite Vocale de la Caméra : Attendre le délai de connexion	Solutions : Appuyez sur le bouton d'alimentation pour redémarrer
État de la Lumière de Travail : Voyant éteint	
État de la Caméra : Si le réseau n'est pas configuré pendant une longue période, l'appareil se mettra automatiquement en veille	

Invite Vocale de la Caméra : Pas de signal LTE	Solutions : <ol style="list-style-type: none">1. Veuillez vérifier si le plan de données de votre carte SIM est disponible2. Le signal 4G actuel est faible, veuillez déplacer la caméra vers un meilleur emplacement de signal
État de la Lumière de Travail : Le voyant rouge continue de clignoter	
État de la Caméra : La carte SIM n'a pas de plan de données ou de différence de signal 4G	

Remarque: Si vous essayez d'ajouter une caméra plusieurs fois et que vous échouez toujours, veuillez envoyer votre commande et votre problème à service@iegeek.com.

06/Charger la Caméra

Il est recommandé de charger complètement la batterie de la caméra avant d'installer la caméra à l'extérieur.

Chargez la caméra avec un adaptateur secteur 5V standard et de haute qualité (non inclus).

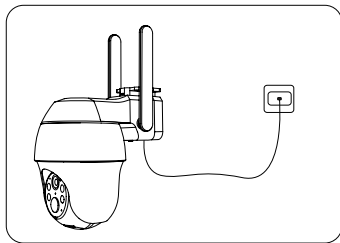
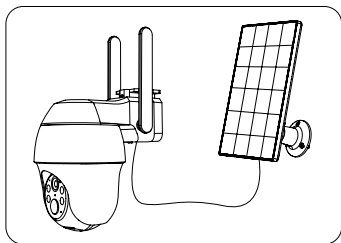

Utilisez le panneau solaire pour charger la caméra.

Rappel de sécurité: n'utilisez pas d'adaptateur secteur autre que 5 V pour charger la caméra et ne la chargez pas à proximité d'un feu ou d'appareils de chauffage. Si la batterie dégage une odeur, de la chaleur, une déformation et d'autres conditions anormales pendant le processus de charge, veuillez arrêter la charge ou l'utiliser immédiatement.

07/ Installer la Caméra

Remarques avant l'installation:

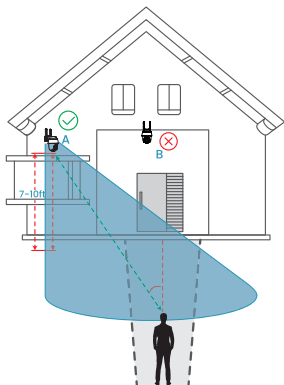

- Installez la caméra à 2-3 mètres (7-10 pieds) au-dessus du sol. La plage de détection de capteur de mouvement serait maximisée à une telle hauteur.
- Pour une détection de mouvement efficace, veuillez installer la caméra angulairement.

REMARQUE: Si un objet en mouvement s'approche verticalement du capteur PIR, la caméra peut ne pas détecter le mouvement.

08/ Plage de Détection du Capteur PIR

La plage de détection PIR peut être personnalisée pour répondre à vos besoins spécifiques. Vous pouvez vous référer au tableau suivant pour le configurer dans les paramètres de l'appareil via l'application iGeek Cam.

Sensibilité	Distance de détection (pour les objets en mouvement et vivants)
Niveau 1-3 (faible)	Jusqu'à 3-5 mètres
Niveau 4-7 (Moyen)	Jusqu'à 5-7 mètres
Niveau 8-10 (élevé)	Jusqu'à 7-10 mètres

09/FAQs

Pour des FAQ plus détaillées, veuillez vous connecter à l'APP, "Me"- "Hele"- "Caméra 4G".

Q: La caméra ne peut pas être allumée?

A: ① Assurez-vous que la caméra est complètement chargée. Veuillez utiliser l'adaptateur secteur 5V pour charger complètement caméra avant de l'allumer.

② Si la caméra est défectueuse ou si de l'eau est entrée, veuillez contacter le service clientèle du fabricant de la marque pour obtenir de l'aide.

Q: Échec de l'ajout de la caméra?

A: Veuillez retourner à la page 9 pour trouver des solutions, ou contactez le service client de la marque pour obtenir de l'aide.

Q: Après la première utilisation pendant un certain temps, la caméra ne parvient pas à se connecter à Internet?

A: ① Veuillez vérifier si le plan de données de la carte SIM est normal, comme les arriérés, l'utilisation excessive des données, etc., et complétez régulièrement le plan de données de la carte SIM.

② Veuillez vérifier si le signal du réseau 4G autour de la caméra est bon et éviter les interférences de signal autour.

Q: La caméra tombe fréquemment et ne peut pas être connectée?

A: Veuillez vérifier si le signal du réseau 4G autour de la caméra est bon et éviter les interférences de signal autour.

Q: Le téléphone portable ne peut-il pas recevoir le message push d'alarme?

A: ① Vérifiez si l'autorisation d'envoi de message de l'application a été activée dans les paramètres système du téléphone mobile.

② Redémarrez le téléphone et le téléphone Android essaiera de vider le cache.

③ Vérifiez si la caméra a la fonction de détection de mouvement activée.

④ Vérifiez si le réseau de la caméra et du téléphone portable est bon.

⑤ Vérifiez si caméra est en ligne et vérifiez si le plan de données de la carte SIM est normal, comme les arriérés, l'utilisation excessive

des données, etc.

Q: Alarme manquée par détection de mouvement?

A: ① Augmentez la sensibilité de détection de mouvement de la caméra.

② Veuillez installer la caméra correctement pour empêcher les intrus de marcher verticalement vers la caméra. (Pour la solution, veuillez vous référer au texte de "Installation de la caméra" dans le manuel).

③ Si vous avez besoin de détecter des véhicules ou des animaux, veuillez désactiver la fonction "AI détection humanoïde".

Q: La caméra peut-elle se connecter au Wi-Fi?

A: Le Wi-Fi n'est pas pris en charge, seul le réseau 4G est pris en charge.

Q: Combien de données la caméra consomme-t-elle par mois?

A: Le trafic consommé par la caméra dépend de la résolution que vous sélectionnez lors de la visualisation. Plus la résolution est élevée, plus la consommation de trafic est importante. Plus le temps de prévisualisation et de lecture vidéo est long, plus la consommation de données est importante. Plus le capteur PIR est déclenché, plus la digestion du flux est importante.

Q: Le forfait de données d'abonnement ne prend pas effet, ou dois-je transférer le forfait et rembourser les frais ?

A: Si vous utilisez la propre carte SIM de caméra, veuillez contacter le service clientèle du fabricant de la marque de caméra pour obtenir de l'aide.

Q: Que faire si l'appareil camera ne reconnaît pas le réseau d'une autre carte SIM?

A: ① Veuillez entrer l'APN de votre carte SIM dans l'APP, veuillez vous référer à la partie 9 - Paramètres APN dans le manuel d'instructions pour la méthode d'ajout (vous devez l'ajouter manuellement car le système n'inclut pas l'APN de certains opérateurs pour le moment) ;

② Assurez-vous que la carte SIM est compatible avec les données 3G/4G ;

③ Assurez-vous que le code PIN de la carte SIM a été supprimé ;

Conseils pratiques:

Il est recommandé d'utiliser en priorité la carte sim fournie avec appareil camera, car il existe trop de types de cartes sim locales pour être compatibles avec toutes.

Si vous avez essayé toutes les étapes, mais toujours sans succès, veuillez envoyer votre commande et votre problème à service@iegeek.com

ESPAÑOL

01	Instrucciones Importantes Antes de Usar.....	46
02	Tarjeta SIM	46
03	Introducción a la Cámara.....	47
04	Descargar y Registrarse APP.....	49
05	Encender la Cámara	50
06	Agregar la Cámara en el Teléfono.....	51
07	Carga la Cámara.....	53
08	Instalar la Cámara	54
09	Rango de Detección del Sensor PIR	55
10	Preguntas Frecuentes	55

01/ Instrucciones Importantes

Antes de Usar

- ① Aunque se hace todo lo posible para que los manuales sean completos y precisos, puede haber algunas discrepancias debido a las actualizaciones del producto.
- ② La tarjeta SIM que viene con la cámara solo proporciona 100M de datos gratis. Agregue el plan de datos en la aplicación a tiempo después de agregar la cámara con éxito.
- ③ Para garantizar el uso continuo de la cámara, asegúrese de que la tarjeta SIM tenga suficientes datos y continúe complementando el plan de datos de la tarjeta SIM.
- ④ La cámara está especialmente diseñada para la detección de movimiento y no se admite la grabación continua de 24 horas, 7 días.
- ⑤ Para garantizar la duración de la batería, no se recomienda apuntar la cámara directamente a la carretera o en un lugar con mucha gente/vehículos.

02/ Tarjeta SIM

Se incluye una tarjeta SIM en la cámara, y esta tarjeta es compatible con las principales redes de operadores de su país.

Tiene la ventaja de la sencillez de uso, recarga de datos rápida y conveniente, fuerte compatibilidad de red, fuerte señal 4G, fuerte compatibilidad con la cámara, no es necesario firmar un acuerdo con el operador, etc. Se recomienda que lo use.

Nota: Esta tarjeta SIM solo es compatible con esta cámara, no la inserte en un teléfono inteligente u otros productos electrónicos.

Si tiene otros problemas con su cámara o necesita acceso a su tarjeta SIM, contáctenos: service@iegeek.com

03/ Introducción a la Cámara

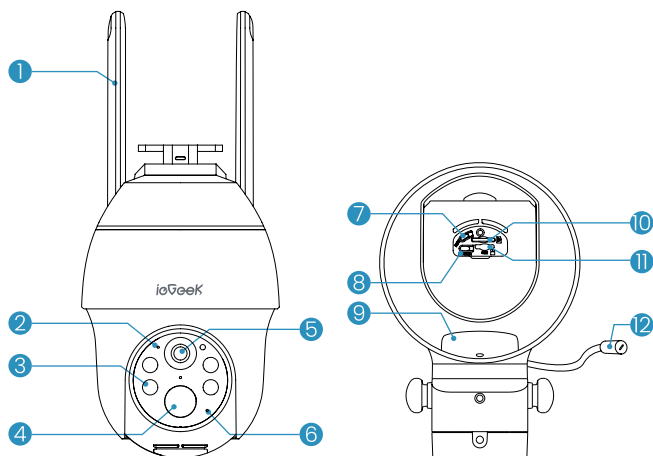

1.	Antena	2.	LED de estado de funcionamiento
3.	Proyector y luz infrarroja	4.	Sensor de movimiento PIR
5.	Lente	6.	Micrófono
7.	Tecla de reinicio	8.	Tecla de encendido
9.	Altavoz	10.	Ranura para tarjeta Micro SD
11.	Ranura para tarjeta SIM	12.	Puerto de carga

Tecla de Encendido	Mantenga presionado el botón de encendido durante 5 segundos para encender la cámara
Tecla de Reinicio	Mantenga presionado RESET durante 5 segundos para restablecer el dispositivo (si ha modificado la configuración, volverá a la configuración predeterminada de fábrica)
Ranura para Tarjetas SD	Admite almacenamiento en tarjeta SD local (hasta 128G)
Luz de encendido	Rojo significa que se está cargando Azul significa que la carga está completa
PIR Sensor	Puede detectar objetos en movimiento a una distancia de hasta 10 metros
Luz de Estado de Trabajo	Luz roja continuamente encendida: red de cámara anormal Luz roja intermitente: esperando conexión de red Las luces rojas y azules parpadean alternativamente: falló el reconocimiento de la tarjeta SIM Luz azul parpadeando lentamente: el reconocimiento de la tarjeta SIM es exitoso Sólida en azul: conexión a internet 4G
Puerto de Carga	Utilice una fuente de alimentación de 5V/2A para cargar la cámara

04/ Descargar y Registrarse APP

Descarga la Aplicación "ieGeek Cam"

Busque "ieGeek Cam" en App Store o Google Play, o escanee el código QR a continuación para descargarlo e instalarlo en su teléfono inteligente.



Nota: para usuarios antiguos, actualice la aplicación a la última versión.

Configuración de Permisos de la Aplicación

Cuando utilice la aplicación por primera vez, active los siguientes 2 permisos.

- ① Permita que "ieGeek Cam" acceda a datos móviles y WLAN; de lo contrario, no podrá agregar dispositivos.
- ② Permita que "ieGeek Cam" reciba mensajes; de lo contrario, el teléfono no recibirá notificaciones automáticas de alerta cuando se active la detección de movimiento o las alertas audibles.

La siguiente es una captura de pantalla de la operación del teléfono celular IOS, el método de apertura de permisos del teléfono celular Android es básicamente el mismo que este método.

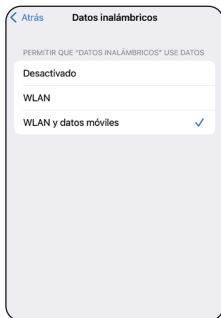
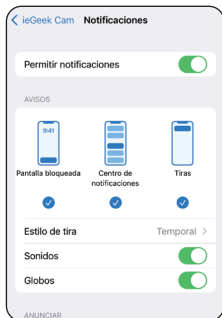

Registrar Cuenta

Los nuevos usuarios deben registrarse por correo electrónico, los pasos concretos son los siguientes:

- ① Haga clic en "Registrarse";
- ② Siga los pasos para completar el registro de su cuenta;
- ③ Iniciar sesión.

Puntas:

- ① Utilice el correo electrónico correcto.
- ② Seleccione el código de país correcto.
- ③ Al registrarse para obtener una nueva cuenta, seleccione la región en la que se encuentra realmente. (Las cámaras no se pueden compartir entre diferentes regiones de registro).

05/ Encender la Cámara

Mantenga presionado el botón de encendido de la cámara durante 5 segundos hasta que el indicador de funcionamiento en el costado de la lente se ilumine en rojo, luego suéltelo.

Espere unos 30 segundos hasta que el indicador de funcionamiento encienda la luz azul intermitente, escuchará el mensaje de voz "Esperando para conectarse", lo que significa que la cámara se ha conectado correctamente a la red 4G, y el siguiente paso es agregar la cámara en la aplicación.

06/ Agregar la Cámara en el Teléfono

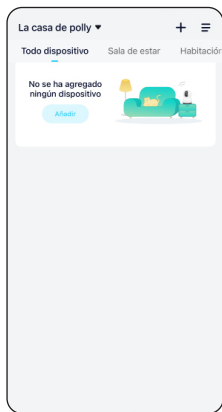

Toque '+' para agregar dispositivo

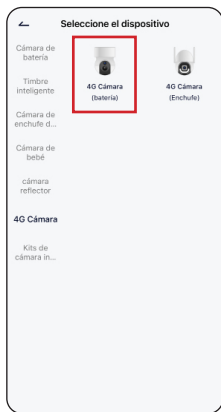

Seleccione cámara 4G

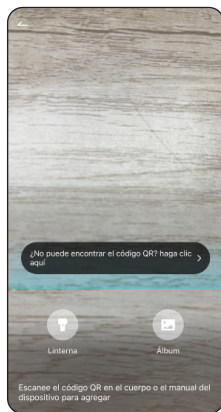

Escanear código O

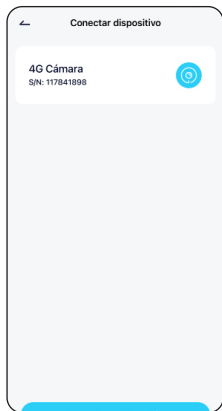

Haga clic para configurar



Insertar tarjeta SIM



Encender la cámara

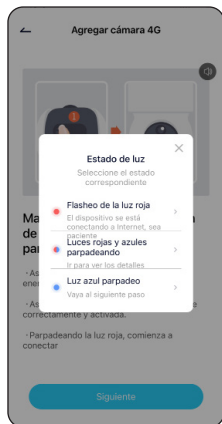

Espera a que la SIM tarjetarecongnition

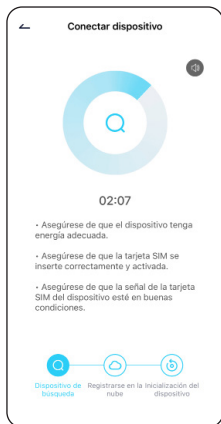

Espera la conexión

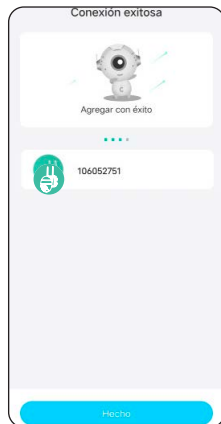

Dispositivo agregado

¿Falló la adición? Consulte lo siguiente para resolver los problemas:

<p>Mensaje de voz de la Cámara : Espera el tiempo de espera de la conexión</p>	<p>Soluciones : Presione el botón de encendido para reiniciar</p>
<p>Estado de la luz de Trabajo : Luz indicadora apagada</p>	
<p>Estado de la Cámara : Si la red no está configurada durante mucho tiempo, el dispositivo se dormirá automáticamente</p>	

Mensaje de voz de la Cámara : Sin señal LTE	Soluciones : 1. Verifique si el plan de datos de su tarjeta SIM está disponible 2. La señal 4G actual es débil, mueva la cámara a una ubicación con mejor señal o reemplace la tarjeta SIM
Estado de la luz de Trabajo : La luz roja sigue parpadeando	
Estado de la Cámara : La tarjeta SIM no tiene plan de datos ni diferencia de señal 4G	

Nota: Si intenta agregar una cámara varias veces y aún falla, envíe un mensaje con su pedido y problema a service@iegeek.com

07/ Carga la Cámara

Se recomienda cargar completamente la batería de la cámara antes de instalar la cámara al aire libre.

Cargue la cámara con un adaptador de corriente de 5 V estándar y de alta calidad (no incluido).

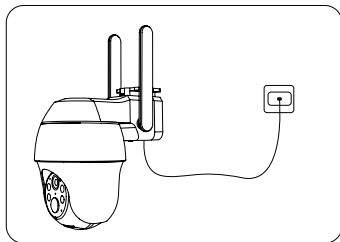
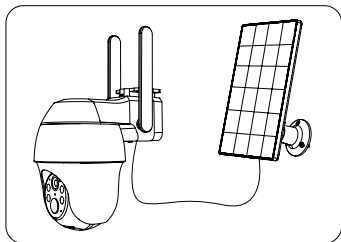

Utilice el panel solar para cargar la cámara.

Recordatorio de seguridad: no utilice un adaptador de corriente que no sea de 5 V para cargar la cámara y no la cargue cerca del fuego o calentadores. Si la batería emite olor, calor, deformación y otras condiciones anormales durante el proceso de carga, deje de cargarla o utilícela inmediatamente.

08/ Instalar la Cámara

Notas antes de la instalación:

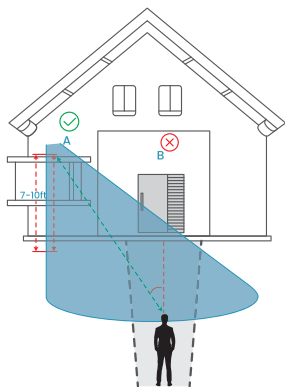

- Instale la cámara a 2 o 3 metros (7 a 10 pies) por encima del suelo. El rango de detección de el sensor de movimiento se maximizaría a tal altura.
- Para una detección de movimiento efectiva, instale la cámara en forma angular.

NOTA: Si un objeto en movimiento se acerca verticalmente al sensor PIR, es posible que la cámara no detecte el movimiento.

09/ Rango de Detección del Sensor PIR

El rango de detección PIR se puede personalizar para satisfacer sus necesidades específicas. Puede consultar la siguiente tabla para configurarlo en Configuración del dispositivo a través de la aplicación ieGeek Cam.

Sensibilidad	Distancia de detección (para objetos vivos y en movimiento)
Nivel 1-3 (Bajo)	Hasta 3-5 metros
Nivel 4-7 (Med.)	Hasta 5-7 metros
Nivel 8-10 (Alto)	Hasta 7-10 metros

10/ Preguntas Frecuentes

Para preguntas frecuentes más detalladas, inicie sesión en la aplicación, "Me" Help "Cámara 4G".

Q: ¿La cámara no se puede encender?

A: ① Asegúrese de que la cámara esté completamente cargada. Utilice el adaptador de corriente de 5 V para cargar completamente la cámara antes de encenderla.
② Si la cámara está defectuosa o ha entrado agua, póngase en contacto con el personal de servicio al cliente del fabricante de la marca para obtener ayuda.

Q: ¿No se pudo agregar la cámara?

A: Vuelva a la página 9 para encontrar soluciones o comuníquese con el personal de servicio al cliente de la marca para obtener ayuda.

Q: Después del primer uso durante un período de tiempo, ¿la cámara no se conecta a Internet?

A: ① Si usa la tarjeta SIM que viene con la cámara, solo se le dará un plan de datos de ilimitado durante tres días gratis. Para evitar quedarse sin datos, reponga el plan de datos en la aplicación a tiempo.

② Verifique si el plan de datos de la tarjeta SIM es normal, como atrasos, uso excesivo de datos, etc., y complemente regularmente el plan de datos de la tarjeta SIM.

③ Verifique si la señal de la red 4G alrededor de la cámara es buena y evite la interferencia de la señal.

Q: ¿La cámara se cae con frecuencia y no se puede conectar?

A: Verifique si la señal de la red 4G alrededor de la cámara es buena y evite la interferencia de la señal.

Q: ¿El teléfono móvil no puede recibir el mensaje de alarma?

A: ① Verifique si el permiso de envío de mensajes de la aplicación se ha habilitado en la configuración del sistema del teléfono móvil.

② Reinicie el teléfono y el teléfono Android intentará borrar el caché.

③ Compruebe si la cámara tiene activada la función de detección de movimiento.

④ Compruebe si la red de la cámara y el teléfono móvil es buena.

⑤ Verifique si la cámara está en línea y verifique si el plan de datos de la tarjeta SIM es normal, como atrasos, uso excesivo de datos, etc.

Q: ¿Alarma perdida de detección de movimiento?

A: ① Aumente la sensibilidad de detección de movimiento de la cámara.

② Instale la cámara correctamente para evitar que los intrusos caminen verticalmente hacia la cámara. (Para la solución, consulte el texto de "Instalación de la cámara" en el manual).

③ Si necesita detectar vehículos o animales, desactive la función "Detección de humanoide AI".

Q: ¿Se puede conectar la cámara a Wi-Fi?

A: No se admite Wi-Fi, solo se admite la red 4G.

Q: ¿Cuántos datos consume la cámara al mes?

A: El tráfico consumido por la cámara depende de la resolución que seleccione al visualizar. A mayor resolución, mayor consumo de tráfico. Cuanto mayor sea el tiempo de reproducción de video y vista previa de video, mayor será el consumo de datos. Cuantas más veces se active el sensor PIR, mayor será la digestión del flujo.

Q: ¿El paquete del plan de datos de suscripción no entra en vigencia o debo transferir el paquete y reembolsar la tarifa?

A: Nuestra cámara contiene una tarjeta SIM. Después de que la recarga se realice correctamente, puede haber un retraso en la activación del paquete de datos. Póngase en contacto con nuestro correo electrónico service@iegeek.com.

ITALIANO

01	Istruzioni Importanti Prima Dell'uso	59
02	Carta SIM	59
03	Introduzione alla Telecamera	60
04	Scarica e Registra l'APP	62
05	Aggiungi la Telecamera al Telefono	63
06	Carica la Telecamera	66
07	Installa la Telecamera	67
08	Gamma di Rilevamento del Sensore PIR.....	67
09	Domande Frequenti	68

01/ Istruzioni Importanti Prima Dell'uso

- ① Sebbene venga fatto ogni sforzo per rendere i manuali completi e accurati, potrebbero esserci alcune discrepanze dovute agli aggiornamenti del prodotto.
- ② La scheda SIM fornita con la telecamera fornisce solo 100 milioni di dati gratuitamente. Si prega di aggiungere il piano dati nell'APP in tempo dopo aver aggiunto correttamente la telecamera.
- ③ Per garantire l'uso continuo della telecamera, assicurarsi che la scheda SIM disponga di dati sufficienti e continuare a integrare il piano dati per la scheda SIM.
- ④ La telecamera è appositamente progettata per il rilevamento del movimento e non supporta lo streaming e la registrazione video 24 ore su 24, 7 giorni su 7.
- ⑤ Per garantire la durata della batteria, non è consigliabile puntare la telecamera direttamente sulla strada o in un luogo con molte persone/veicoli.

02/ Carta SIM

Nella confezione della telecamera è inclusa una scheda SIM che supporta le principali reti di operatori del tuo paese.

Presenta i vantaggi di una facile installazione e utilizzo, ricarica dei dati rapida e conveniente, forte compatibilità di rete, forte segnale 4G, forte compatibilità con la telecamera, nessuna necessità di firmare un accordo con l'operatore, ecc. Si consiglia di utilizzarlo.

Nota: se hai problemi con la fotocamera o hai bisogno di accedere alla tua scheda SIM, contattaci: service@iegeek.com.

03/ Introduzione alla Telecamera

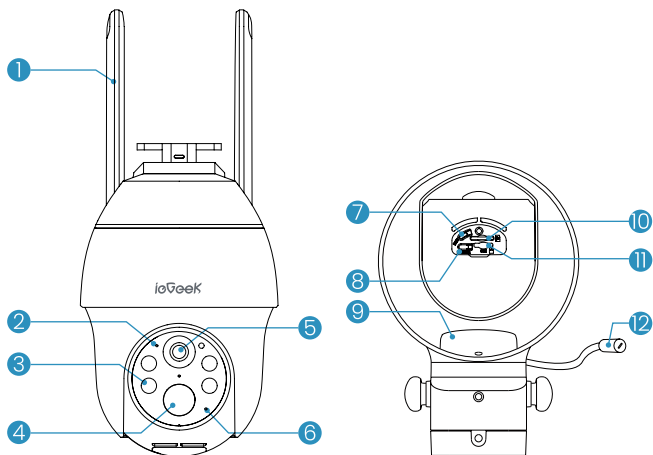

1.	Antenna	2.	LED di stato di lavoro
3.	Spotlight e luce infrarossa	4.	Sensore di movimento PIR
5.	Lente	6.	Microfono
7.	Tasto di reset	8.	Tasto di accensione
9.	Altoparlante	10.	Slot per schede Micro SD
11.	Slot per schede SIM	12.	Porta di ricarica

Tasto di Accensione	Tenere premuto il pulsante di accensione per 5 secondi per accendere la telecamera
Chiave di Ripristino	Tieni premuto RESET per 5 secondi per ripristinare il dispositivo (se hai modificato le impostazioni, torneranno alle impostazioni predefinite di fabbrica)
Slot per Scheda SD	Supporta l'archiviazione su scheda SD locale (fino a 128G)
Potenza Luce	Rosso significa che la ricarica è in corso Blu significa che la ricarica è completa
Sensore PIR	Può rilevare oggetti in movimento fino a 10 metri di distanza
Luce di Stato di Lavoro	Luce rossa fissa: rete della telecamera anomala Luce rossa lampeggiante: in attesa di connessione alla rete Le luci rosse e blu lampeggiano alternativamente: riconoscimento della scheda SIM non riuscito Luce blu che lampeggia lentamente: il riconoscimento della carta SIM è andato a buon fine Fisso sul blu: connessione internet 4G.
Porta di Ricarica	Utilizzare un alimentatore da 5 V/2 A per caricare la telecamera

04/ Scarica e Registra l'APP

Scarica l'APP "ieGeek Cam"

Cerca "ieGeek Cam" in App Store o Google Play, oppure scansiona il codice QR qui sotto per scaricarlo e installarlo sul tuo smartphone.



Nota: per i vecchi utenti, aggiornare l'APP all'ultima versione.

Impostazioni di Autorizzazione Dell'APP

Quando si utilizza l'applicazione per la prima volta, attivare le seguenti 2 autorizzazioni.

- ① Consenti a "ieGeek Cam" di accedere ai dati del cellulare mobile e alla WLAN, altrimenti non sarai in grado di aggiungere dispositivi.
- ② Consenti a "ieGeek Cam" di ricevere messaggi, altrimenti il telefono non riceverà notifiche push di avviso quando vengono attivati il rilevamento del movimento o gli avvisi acustici.

Di seguito è riportato uno screenshot del funzionamento del telefono cellulare IOS, il metodo di apertura delle autorizzazioni del telefono cellulare Android è sostanzialmente lo stesso di questo metodo.

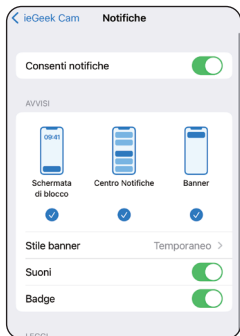

Registra un Account

I nuovi utenti devono registrarsi via e-mail, i passaggi concreti sono i seguenti:

- ① Clicca su "Registrati";
- ② Segui i passaggi per completare la registrazione del tuo account;
- ③ Accedi.

Consigli:

- ① Si prega di utilizzare l'e-mail corretta.
- ② Selezionare il prefisso internazionale corretto.
- ③ Quando ti registri per un nuovo account, seleziona la regione in cui ti trovi effettivamente. (Le telecamere non possono essere condivise tra diverse regioni di registrazione.)

05/ Aggiungi la Telecamera al Telefono

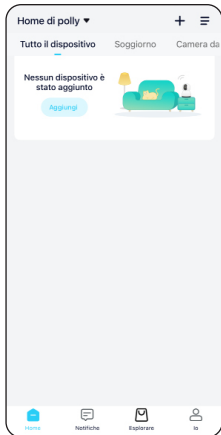

Tocca "+" per aggiungere dispositivo

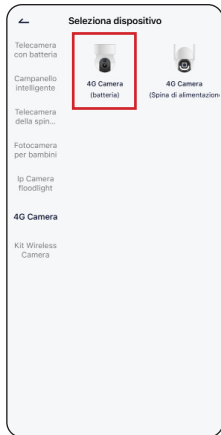

Seleziona Fotocamera 4G

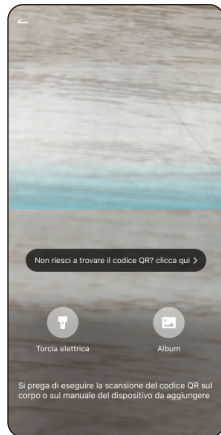

Scansiona il codice QR

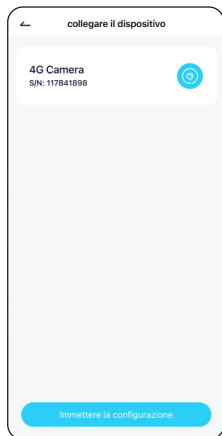

Fare clic per configurare



Inserire la scheda SIM



Apri la telecamera

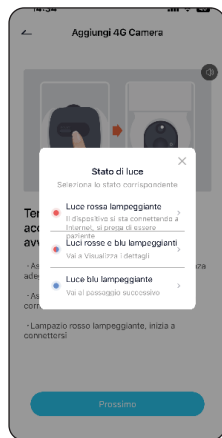

Attendi il riconoscimento della carta SIM

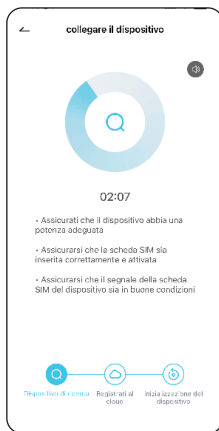

Attendere la connessione

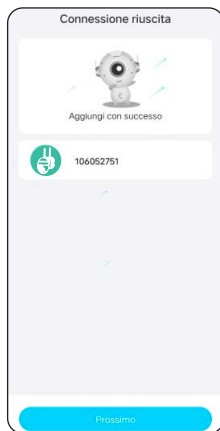

Dispositivo aggiunto

Aggiunta fallita? Fare riferimento a quanto segue per risolvere i problemi:

Messaggio Vocale della Telecamera : Attendere il timeout della connessione	Soluzioni : Premere il pulsante di accensione per riavviare
Stato della Luce di Lavoro : Spia spenta	
Stato della Telecamera : Se la rete non è configurata per molto tempo, il dispositivo andrà automaticamente in sospensione	

Messaggio Vocale della Telecamera : Nessun segnale LTE	Soluzioni : 1. Controlla se il piano dati della tua scheda SIM è disponibile 2. Il segnale 4G corrente è debole, sposta la videocamera in una posizione con segnale migliore
Stato della Luce di Lavoro : La luce rossa continua a lampeggiare	
Stato della Telecamera : La scheda SIM non ha un piano dati o una differenza di segnale 4G	

Nota: se provi ad aggiungere una videocamera più volte e ancora non riesci, invia un messaggio con l'ordine e il problema a service@iegeek.com

06/Carica la Telecamera

Si consiglia di caricare completamente la batteria della videocamera prima di installare la videocamera all'aperto.

Carica la telecamera con un alimentatore da 5 V standard e di alta qualità (non incluso).

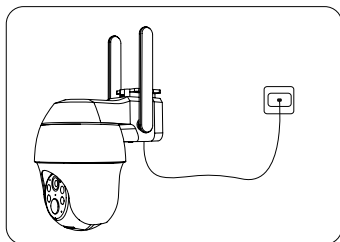
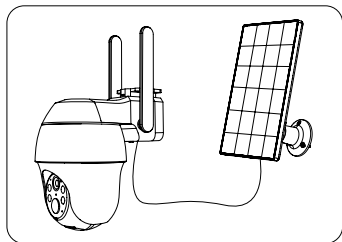

Usa il pannello solare per caricare la telecamera.

Promemoria per la sicurezza: non utilizzare un adattatore di alimentazione diverso da 5 V per caricare la telecamera e non caricare vicino a fuoco e riscaldatori. Se la batteria emette odore, calore, deformazione e altre condizioni anomale durante il processo di ricarica, interrompere la ricarica o utilizzarla immediatamente.

07/Installa la Telecamera

Note prima dell'installazione:

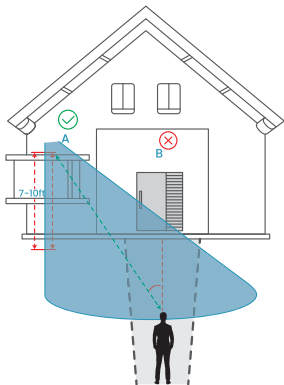

- Installare la telecamera a 2-3 metri (7-10 piedi) dal suolo. Il campo di rilevamento di il sensore di movimento sarebbe massimizzato a tale altezza.
- Per un rilevamento del movimento efficace, installare la telecamera in modo angolare.

NOTA: se un oggetto in movimento si avvicina verticalmente al sensore PIR, la telecamera potrebbe non rilevare il movimento.

08/ Gamma di Rilevamento del Sensore PIR

Il raggio di rilevamento PIR può essere personalizzato per soddisfare le vostre esigenze specifiche. È possibile fare riferimento alla tabella seguente per configurarlo in Impostazioni dispositivo tramite l'app ieGeek Cam.

Sensibilità	Distanza di rilevamento (per oggetti in movimento e vivi)
Livello 1-3 (basso)	Fino a 3-5 metri
Livello 4-7 (medio)	Fino a 5-7 metri
Livello 8-10 (alto)	Fino a 7-10 metri

09/ Domande Frequenti

Per domande frequenti più dettagliate, accedi all'APP, "Me" Aiuto "4G Camera".

Q: La telecamera non può essere accesa?

A: ① Assicurarsi che la telecamera sia completamente carica. Utilizzare l'adattatore di alimentazione da 5 V per caricare completamente la telecamera prima di accenderla.

② Se la telecamera è difettosa o è entrata dell'acqua, contattare il personale del servizio clienti del produttore del marchio per assistenza.

Q: Impossibile aggiungere la telecamera?

A: Torna a pagina 9 per trovare soluzioni o contatta il personale del servizio clienti del marchio per assistenza.

Q: Dopo il primo utilizzo per un periodo di tempo, la telecamera non riesce a connettersi a Internet?

A: ① Verificare se il piano dati della scheda SIM è normale, ad esempio arretrati, utilizzo eccessivo dei dati, ecc., e integrare regolarmente il piano dati per la scheda SIM.

② Verificare se il segnale di rete 4G intorno alla telecamera è buono ed evitare interferenze di segnale.

Q: La telecamera cade frequentemente e non può essere collegata?

A: Verificare se il segnale di rete 4G intorno alla telecamera è buono ed evitare interferenze di segnale.

Q: Il telefono cellulare non può ricevere il messaggio push di allarme?

A: ① Controlla se l'autorizzazione push dei messaggi dell'app è stata abilitata nelle impostazioni di sistema del telefono cellulare.

② Riavvia il telefono e il telefono Android proverà a svuotare la cache.

③ Controllare se la telecamera ha la funzione di rilevamento del movimento abilitata.

④ Controllare se la rete della telecamera e del telefono cellulare è buona.

⑤ Controlla se la videocamera è online e controlla se il piano dati della scheda SIM è normale, come arretrati, utilizzo eccessivo di dati, ecc.

Q: Rilevamento del movimento mancato allarme?

A: ① Aumentare la sensibilità di rilevamento del movimento della telecamera.

② Installare correttamente la telecamera per evitare che gli intrusi camminino verticalmente verso la telecamera. (Per la soluzione, fare riferimento al testo di "Installazione della telecamera" nel manuale).

③ Se è necessario rilevare veicoli o animali, disattivare la funzione "Rilevamento umanoide AI".

Q: La telecamera può connettersi al Wi-Fi?

A: Il Wi-Fi non è supportato, è supportata solo la rete 4G.

Q: Quanti dati consuma la telecamera al mese?

A: Il traffico consumato dalla telecamera dipende dalla risoluzione selezionata durante la visualizzazione. Maggiore è la risoluzione, maggiore è il consumo di traffico. Più lungo è il video di anteprima e il tempo di riproduzione del video, maggiore è il consumo di dati. Più volte viene attivato il sensore PIR, maggiore è la digestione del flusso.

Q: Il pacchetto del piano dati in abbonamento non ha effetto o devo trasferire il pacchetto e rimborsare la tariffa?

A: Se si utilizza la scheda SIM della telecamera, contattare il personale del servizio clienti del produttore della telecamera per assistenza.

Q: Impossibile connettersi utilizzando una scheda portatile non locale?

A: ① Inserisci manualmente la scheda SIM nell'APN nell'APP. L'APN di alcuni operatori non è stato ancora utilizzato, quindi è necessario aggiungerlo manualmente. Per il metodo di aggiunta, fare riferimento a 9.Impostazioni APN;

② Assicurati che siano dati 3/4G;

③ Assicurarsi che il codice PIN della carta SIM sia stato rilasciato;

Suggerimenti gentili:

Cerca di non utilizzare carte o operatori virtuali; ci sono troppi tipi di carte locali, e non possono essere completamente compatibili, prova ad usare le nostre carte;

Se hai provato tutti i passaggi, ma ancora senza successo, invia un messaggio con il tuo ordine e il problema a service@iegeek.com



FR

Vous êtes responsable de remettre tous les appareils électriques et électroniques usagés à des points de collecte correspondants.

Pour en savoir plus : www.quefairedemesdechets.fr



FR



ÉTUI



FR

Les piles et batteries se recyclent

A DÉPOSER EN MAGASIN

A DÉPOSER EN DÉCHÈTERIE



OU

Points de collecte sur www.quefairedemesdechets.fr



HUMISS TRADING S.L
Calle Luis Buñuel 12-3A, Madrid,
28018, Spain
eugpres@outlook.com
+3461317772

SeasMew Accounting Ltd
Electric Avenue Vision 25, London,
Enfield EN3 7GD
info@seasmew.net
+447399548608



FCC ID: 2AYZFS1
Made in China Model: S11

This device complies with Part 15 of the FCC Rules. Operation is subject to the following two conditions:
(1) This device may not cause harmful interference, and
(2) this device must accept any interference received, including interference that may cause undesired operation.

The first part of the document discusses the importance of maintaining accurate records of all transactions. This includes not only sales and purchases but also any other financial activities that may occur during the course of the business. It is essential to ensure that all records are kept in a clear and organized manner, and that they are readily accessible for review and audit.

In addition, it is important to ensure that all records are kept for the appropriate period of time. This is typically determined by the relevant tax authorities, and it is essential to ensure that all records are kept for the full period required. Failure to do so may result in penalties and fines, and it may also make it difficult to defend the business in the event of an audit.

The second part of the document discusses the importance of ensuring that all transactions are properly recorded and accounted for. This includes ensuring that all sales and purchases are recorded in a timely and accurate manner, and that all other financial activities are also properly recorded. It is essential to ensure that all records are kept in a clear and organized manner, and that they are readily accessible for review and audit.

In addition, it is important to ensure that all records are kept for the appropriate period of time. This is typically determined by the relevant tax authorities, and it is essential to ensure that all records are kept for the full period required. Failure to do so may result in penalties and fines, and it may also make it difficult to defend the business in the event of an audit.

The third part of the document discusses the importance of ensuring that all transactions are properly recorded and accounted for. This includes ensuring that all sales and purchases are recorded in a timely and accurate manner, and that all other financial activities are also properly recorded. It is essential to ensure that all records are kept in a clear and organized manner, and that they are readily accessible for review and audit.

In addition, it is important to ensure that all records are kept for the appropriate period of time. This is typically determined by the relevant tax authorities, and it is essential to ensure that all records are kept for the full period required. Failure to do so may result in penalties and fines, and it may also make it difficult to defend the business in the event of an audit.

ieGeek



www.iegeek.com

ieGeek and ieGeek logo are trademarks of Shenzhen Globalebuy Co., Ltd, registered in the United States and other countries. All right reserved.